



# FEDERATION INTERNATIONALE DU SPORT AUTOMOBILE

Homologation N°

A-5036

Groupe  
Group **A/B**

FICHE D'HOMOLOGATION CONFORME A L'ANNEXE J DU CODE SPORTIF INTERNATIONAL  
HOMOLOGATION FORM IN ACCORDANCE WITH APPENDIX J OF THE INTERNATIONAL SPORTING CODE

Homologation valable à partir du \_\_\_\_\_ -1.3.82 1982 \_\_\_\_\_ en groupe \_\_\_\_\_ A  
Homologation valid as from \_\_\_\_\_ in group \_\_\_\_\_

Photo A

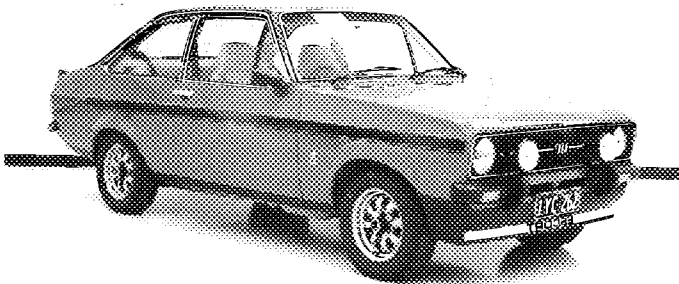
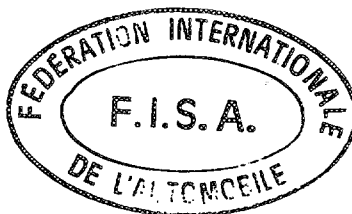

Photo B



## 1. DEFINITIONS / DEFINITIONS

101. Constructeur  
Manufacturer FORD MOTOR CO LTD
102. Dénomination(s) commerciale(s) – Modèle et type  
Commercial name(s) – Type and model Escort RS2000 AVS
103. Cylindres totale  
Cylinder capacity 1993 cm<sup>3</sup>
104. Mode de construction  
Type of car construction  
 séparée, matériau du châssis  
 separate, material of chassis Steel  
 monocoque  
 unitary construction
105. Nombre de volumes  
Number of volumes 3
106. Nombre de places  
Number of places 4



Marque FORD Modèle RS2000 N° Homol. A-5036  
 Make \_\_\_\_\_ Model \_\_\_\_\_

**2. DIMENSIONS, POIDS / DIMENSIONS, WEIGHT**

202. Longueur hors-tout 4150 mm ± 1%  
 Overall length \_\_\_\_\_

203. Largeur hors-tout 1607 mm ± 1% Endroit de la mesure At door handles  
 Overall width \_\_\_\_\_ Where measured \_\_\_\_\_

204. Largeur de la carrosserie: a) A la hauteur de l'axe AV 1565 mm ± 1%  
 Width of bodywork: At front axle \_\_\_\_\_  
 b) A la hauteur de l'axe AR 1600 mm ± 1%  
 At rear axle \_\_\_\_\_

206. Empattement: a) Droit 2407 mm ± 1% b) Gauche: 2407 mm ± 1%  
 Wheelbase: Right \_\_\_\_\_ Left: \_\_\_\_\_

209. Porte-à-faux: a) AV: 822 mm ± 1% b) AR: 921 mm ± 1%  
 Overhang: Front: \_\_\_\_\_ Rear: \_\_\_\_\_

210. Distance «G» (volant — paroi de séparation AR) 1490 mm ± 1%  
 Distance «G» (steering wheel — rear bulkhead) \_\_\_\_\_

3. MOTEUR / ENGINE: (En cas de moteur rotatif, voir Article 335 sur fiche complémentaire).  
 (In case of rotative engine, see Article 335 on complementary form)

301. Emplacement et position du moteur: Front, Longitudinal, vertical  
 Location and position of the engine: \_\_\_\_\_

303. Cycle 4 stroke  
 Cycle \_\_\_\_\_

304. Suralimentation /non; type No  
 Supercharging /no; type \_\_\_\_\_  
 (En cas de suralimentation, voir également l'Article 334 sur fiche complémentaire)  
 (In case of supercharging, see also Article 334 on complementary form)

305. Nombre et disposition des cylindres 4 in line  
 Number and layout of the cylinders \_\_\_\_\_

306. Mode de refroidissement liquid  
 Cooling system \_\_\_\_\_

307. Cylindrée: a) Unitaire 498 cm<sup>3</sup> b) Totale 1993 cm<sup>3</sup>  
 Cylinder capacity: a) Unitary \_\_\_\_\_ b) Total \_\_\_\_\_  
 c) Totale maximum autorisée\* 1999,9 cm<sup>3</sup> \*(Cette indication n'est pas à considérer en Gr. N)  
 c) Maximum total allowed\* \_\_\_\_\_ \*(This indication is not to be considered in Gr. N)

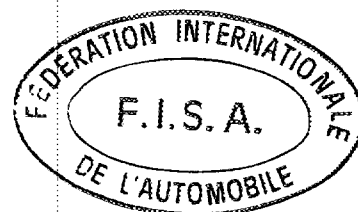

Marque Make FORD Modéle Model RS2000 N° Homol. A-5036

312. Matériau du bloc-cylindres  
Cylinder block material Cast iron alloy
313. Chemises: a) /non  
Sleeves: /no c) Type Type
314. Alésage Bore 90,8 mm
315. Alésage maximum autorisé Maximum bore allowed 90,95 mm (Cette indication n'est pas à considérer en Gr N) (This indication is not to be considered in Gr N)
316. Course Stroke 76,9 mm
318. Bielle: a) Matériau Material Forged steel b) Type de la tête de bielle Big end type Split housing  
c) Diamètre intérieur de la tête de bielle (sans coussinets) Interior diameter of the big end (without bearings) 55,0 mm  $\pm 0.1\%$   
d) Longueur entre axes Length between the axes 127 mm ( $\pm 0.1$  mm) e) Poids minimum Minimum weight 660 g
319. vilebrequin: a) Type de construction Type of manufacture One piece  
b) Matériau Material Cast iron alloy  
c)  coulé moulé  estampé stamped d) Nombre de paliers Number of bearings 5  
e) Type de paliers Type of bearings Plain bearings  
f) Diamètre des paliers Diameter of bearings 57,0 mm  $\pm 0.2\%$   
g) Matériau des chapeaux des paliers Bearing caps material Cast iron alloy  
h) Poids minimum du vilebrequin nu Minimum weight of the bare crankshaft 12,100 g
320. Volant moteur: a) Matériau Material Cast iron alloy  
Flywheel: b) Poids minimum avec couronne de démarreur Minimum weight of the flywheel with starter ring 7,620 g
321. Culasse: a) Nombre de culasses Number of cylinderheads 1 b) Matériau Material Cast iron alloy  
Cylinderhead:
323. Alimentation par carburateur(s): a) Nombre de carburateurs Number of carburetors 1  
Fuel feed by carburettor(s): b) Type Type Double barrel c) Marque et modèle Make and model Weber DCAV

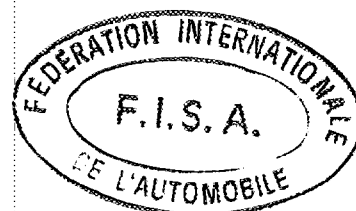

Marque FORD Modèle RS2000 N° Homol. A-5036  
 Make \_\_\_\_\_ Model \_\_\_\_\_

- d) Nombre de passages de gaz par carburateur 2  
 Number of mixture passages per carburettor \_\_\_\_\_
- e) Diamètre maximum de la tubulure de gaz à la sortie du carburateur 36 mm  
 Maximum diameter of the flange hole of the carburettor exit port \_\_\_\_\_ mm
- f) Diamètre du diffuseur au point d'étranglement maximum 27 mm  
 Diameter of the venturi at the narrowest point \_\_\_\_\_ mm

**24. Alimentation par injection:**

- Fuel feed by injection:**
- a) Marque: \_\_\_\_\_  
 Manufacturer: \_\_\_\_\_
- b) Modèle du système d'injection: \_\_\_\_\_  
 Model of injection system: \_\_\_\_\_
- c) Mode de dosage du carburant:  mécanique  électronique  hydraulique  
 Kind of fuel measurement:  mechanical  electronical  hydraulical
- c1) Plongeur oui/non c2) Mesure du volume d'air oui/non  
 Piston pump yes/no Measurement of air volume yes/no
- c3) Mesure de la masse d'air oui/non c4) Mesure de la vitesse de l'air oui/non  
 Measurement of air mass yes/no Measurement of air speed yes/no
- c5) Mesure de la pression d'air oui/non Quelle est la pression de réglage? \_\_\_\_\_ bars  
 Measurement of air pressure yes/no Which pressure is taken for measurement? \_\_\_\_\_ bars
- d) Dimensions effectives du point de mesure au(x) papillon(s) ou au(x) tiroir(s) d'étranglement \_\_\_\_\_ mm  
 Effective dimensions of measure position in the throttle area \_\_\_\_\_ mm
- e) Nombre des sorties effectives de carburant \_\_\_\_\_  
 Number of effective fuel outlets \_\_\_\_\_
- f) Position des soupapes d'injection:  Canal d'admission  Culasse  
 Position of injection valves:  Inlet manifold  Cylinderhead
- g) Parties du système d'injection servant au dosage du carburant \_\_\_\_\_  
 Statement of fuel measuring parts of injection system \_\_\_\_\_

**25. Arbre à cames:**

- a) Nombre 1  
 Camshaft: Number \_\_\_\_\_
- b) Emplacement In cylinder head  
 Location \_\_\_\_\_
- c) Système d'entraînement Notched belt  
 Driving system \_\_\_\_\_
- d) Nombre de paliers par arbre 3  
 Number of bearings for each shaft \_\_\_\_\_
- f) Système de commande des soupapes Oscillating lever  
 Type of valve operation \_\_\_\_\_

**26. Distribution:**

- e) Levée maximum des soupapes 10,2 mm  
 Timing: Maximum valve lift Admission Inlet \_\_\_\_\_ mm Echappement Exhaust 10,2 mm
- avec jeu de 0,2 mm with clearance \_\_\_\_\_ mm

**7. Admission:**

- a) Matériau du collecteur Aluminium alloy  
 Inlet: Material of the manifold \_\_\_\_\_
- b) Nombre d'éléments du collecteur 1  
 Number of manifold elements \_\_\_\_\_
- c) Nombre de soupapes par cylindre 1  
 Number of valves per cylinder \_\_\_\_\_
- d) Diamètre maximum des soupapes 42,5 mm  
 Maximum diameter of the valves \_\_\_\_\_ mm
- e) Diamètre de la tige de soupape 8 mm  
 Diameter of the valve stem \_\_\_\_\_ mm
- f) Longueur de la soupape 111 + 2 mm  
 Length of the valve \_\_\_\_\_ mm
- g) Type des ressorts de soupape Coil  
 Type of valve springs \_\_\_\_\_

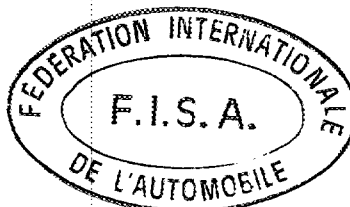

Marque FORD Modèle RS2000 N° Homol. A-5036  
Make \_\_\_\_\_ Model \_\_\_\_\_

328. Echappement: a) Matériau du collecteur Cast iron alloy  
Exhaust: Material of the manifold \_\_\_\_\_  
b) Nombre d'éléments du collecteur 1 d) Nombre de soupapes par cylindre 1  
Number of manifold elements \_\_\_\_\_ Number of valves per cylinder \_\_\_\_\_  
e) Diamètre maximum des soupapes 36,2 mm f) Diamètre de la tige de soupape 8 mm  
Maximum diameter of the valves \_\_\_\_\_ Diameter of the valve stem \_\_\_\_\_  
g) Longueur de la soupape 111 + 2 mm h) Type des ressorts de soupape Coil  
Length of the valve \_\_\_\_\_ Type of valve springs \_\_\_\_\_

330. Système d'allumage: a) Type Battery operated  
Ignition system: Type \_\_\_\_\_  
b) Nombre de bougies par cylindre 1 c) Nombre de distributeurs 1  
Number of plugs per cylinder \_\_\_\_\_ Number of distributors \_\_\_\_\_  
333. Système de lubrification: a) Type Compartmented  
Lubrification system: Type Wet sump b) Nombre de pompes à huile 1  
Number of oil pumps \_\_\_\_\_

#### 4. CIRCUIT DE CARBURANT / FUEL CIRCUIT

401. Réservoir: a) Nombre 1 b) Emplacement In rear compartment  
Fuel tank: Number \_\_\_\_\_ Location \_\_\_\_\_  
c) Matériau Mild steel, treated d) Capacité maximum 41 L  
Material \_\_\_\_\_ Maximum capacity \_\_\_\_\_

#### 5. EQUIPEMENT ELECTRIQUE / ELECTRICAL EQUIPEMENT

501. Batterie(s): a) Nombre 1  
Battery(ies): Number \_\_\_\_\_

#### 6. TRANSMISSION / DRIVE

601. Roues motrices:  avant  arrière  
Driving wheels:  front  rear

602. Embrayage: b) Système de commande Cable release (mechanical)  
Clutch: Drive system \_\_\_\_\_  
c) Nombre de disques 1  
Number of plates \_\_\_\_\_

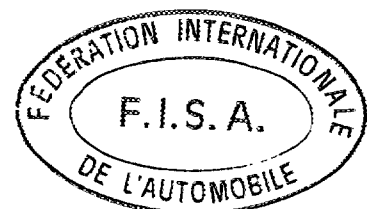

Marque / Make: **FORD**      Modèle / Model: **RS2000**      N° Homol.: **A-5036**

603 Boîte de vitesses: a) Emplacement / Location: **Behind engine**  
 Gear-box: Location

b) Marque «manuelle» / «Manual» make: **Ford**      c) Marque «automatique» / «Automatic» make:

d) Emplacement de la commande / Location of the gear lever: **Central on floor**

e) Rapports / Ratios

	Manuelle / Manual			Automatique / Automatic			B.V. suppl. / Additional G.B.		
	rappports ratio	nombre de dents / number of teeth	synchro.	rappports ratio	nombre de dents / number of teeth	synchro.	rappports ratio	nombre de dents / number of teeth	synchro.
1	3,65	$\frac{29}{15}$	X				2,54	$\frac{27}{17}$	X
2	1,97	$\frac{25}{24}$	X				1,66	$\frac{25}{24}$	X
3	1,37	$\frac{21}{29}$	X				1,255	$\frac{25}{24}$	X
4	1,00	Direct	X				1,00	Direct	X
5									
AR/R	3,66	$\frac{31}{16}$					3,1	$\frac{31}{16}$	
Constante		$\frac{34}{18}$						$\frac{32}{20}$	
Constant									

f) Grille de vitesse / Gear change gate

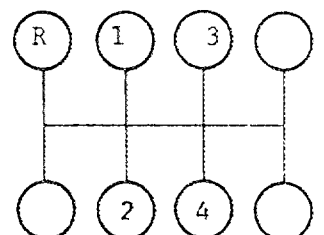
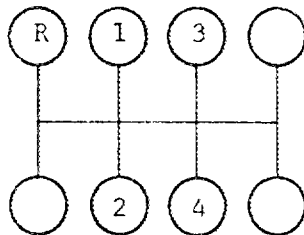

604. Surmultiplication: a) Type / Type: **N.A.**  
 Overdrive: Type

b) Rapport / Ratio: **N.A.**      c) Nombre de dents / Number of teeth: **N.A.**

d) Utilisable avec les vitesses suivantes / Usable with the following gears: **N.A.**

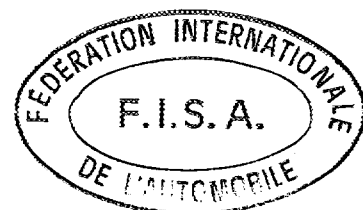

Marque  
Make

FORD

Modèle  
Model

RS2000

N° Homol

A-5030

605. Couple final:

Final drive:

- a) Type du couple final  
Type of final drive
- b) Rapport  
Ratio
- c) Nombre de dents  
Teeth number
- d) Type de limitation de différentiel (si prévu)  
Type of differential limitation (if provided)

AV / Front	AR / Rear
	Hypoid
	3,56
	32:9

- e) Rapport de la boîte de transfert  
Ratio of the transfer box

N.A.

606. Type de l'arbre de transmission  
Type of the transmission shaft

2 piece with hooks & sliding joints

7. SUSPENSION / SUSPENSION

- 701. Type de suspension: a) AV / Front

MacPherson Strut - Independent

Type of suspension:

b) AR / rear Rigid axle - leaf springs + radius rods

- 702. Ressorts hélicoïdaux: AV: oui/  
Helicoidal springs: Front: yes/ AR: /non  
Rear: /no

- 703. Ressorts à lames: AV: /non  
Leaf springs: Front: /no AR: oui/  
Rear: yes/

- 704. Barre de torsion: AV: /non  
Torsion bar: Front: /no AR: non  
Rear: /no

- 705. Autre type de suspension: Voir photo/dessin en page 15  
Other type of suspension: See photo or drawing on page 15

N.A.

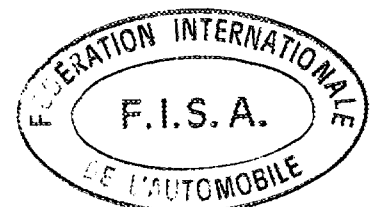

Marque FORD Modèle RS2000 N° Homol. A-5036  
 Make \_\_\_\_\_ Model \_\_\_\_\_

**707. Amortisseurs:**

**Shock Absorbers:**

- a) Nombre par roue  
Number per wheel  
b) Type  
Type  
c) Principe de fonctionnement  
Working principle

Avant / Front	Arrière / Rear
1	1
Telescopic	Telescopic
Hydraulic	Hydraulic

**8. TRAIN ROULANT / RUNNING GEAR:**

**801. Roues:** a) Diamètre AV 13 / 330 mm AR 13 / 330 mm  
**Wheels:** Diameter Front \_\_\_\_\_ / \_\_\_\_\_ mm Rear \_\_\_\_\_ / \_\_\_\_\_ mm

**803. Freins:** a) Système de freinage Hydraulic  
**Brakes:** Braking system \_\_\_\_\_  
 b) Nombre de maître-cylindres Tandem b1) Alésage 2 x 20,6 mm  
 Number of master cylinders \_\_\_\_\_ Bore \_\_\_\_\_ mm  
 c) Servo-frein oui/ c1) Marque et type Ford Vacuum  
 Power assisted brakes yes/ Make and type \_\_\_\_\_  
 d) Régulateur de freinage oui. d1) Emplacement Near rear axle  
 Braking adjuster yes. Location \_\_\_\_\_

e) Nombre de cylindres par roue:  
Number of cylinders per wheel:

e1) Alésage  
Bore

f) Freins à tambours:

Drum brakes:

f1) Diamètre intérieur  
Interior diameter

f2) Nombre de mâchoires par roue.  
Number of shoes per wheel

f3) Surface de freinage  
Braking surface

f4) Largeur des garnitures  
Width of the shoes

g) Freins à disques:

Disc brakes:

g1) Nombres de sabots par roue  
Number of pads per wheel

g2) Nombre d'étriers par roue  
Number of calipers per wheel

Avant / Front	Arrière / Rear
2	1
54 mm	19,05 mm
_____ mm (± 1,5 mm)	228,6 mm (± 1,5 mm)
_____	2
_____ cm <sup>2</sup>	319,5 cm <sup>2</sup>
_____ mm	44,5 mm
2	_____
1	_____

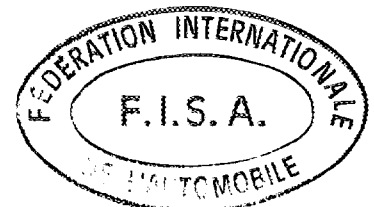



Marque FORD Modèle RS2000 N° Homol. A-5030  
 Make \_\_\_\_\_ Model \_\_\_\_\_

	AV / Front	AR / Rear
g3) Matériau des étriers Caliper material	Cast iron	
g4) Epaisseur maximale du disque Maximum disc thickness	12,8 mm	
g5) Diamètre extérieur du disque Exterior diameter of the disc	247,5 mm (± 1 mm)	
g6) Diamètre extérieur de frottement des sabots Exterior diameter of the shoe's rubbing surface	245 mm	
g7) Diamètre intérieur de frottement des sabots Interior diameter of the shoe's rubbing surface	139,8 mm	
g8) Longueur hors-tout des sabots Overall length of the shoes	76,6 mm	
g9) Disques ventilés Ventilated disc	/non /no	oui/non yes/no
g10) Surface de freinage par roue Braking surface per wheel	655,2 cm <sup>2</sup>	

h) Frein de stationnement: Parking brake: \_\_\_\_\_  
 h2) Emplacement de la commande Location of the lever Central on floor  
 h1) Système de commande Command system Lever + cable  
 h3) Effet sur roues On which wheels AV Front AR Rear Rear

804. Direction: a) Type Rack & pinion  
 Steering: Type \_\_\_\_\_  
 b) Rapport Ratio 18:1 c) Servo-assistance /non  
 Power assisted /no

**9. CARROSSERIE / BODYWORK**

901. Intérieur: a) Ventilation oui/ Heating oui/  
 Interior: Ventilation yes/ Heating yes/  
 f) Toit ouvrant optionnel oui/ f1) Type Steel sliding  
 Sun roof optional yes/ Type \_\_\_\_\_  
 f2) Système de commande Rotating handle  
 Command system \_\_\_\_\_  
 g) Système d'ouverture des vitres latérales: AV/Front: Rotating handle  
 Opening system for the side windows: AR/Rear: Rotating handle

902. Extérieur: a) Nombre de portes 2 b) Hayon AR non  
 Exterior: Number of doors \_\_\_\_\_ Rear tailgate /no  
 c) Matériau des portières: AV/Front: Mild steel sheet  
 Door material: AR/Rear: N.A.

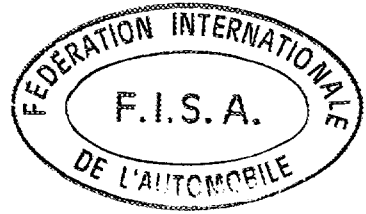

Marque FORD Modèle RS 2000 N° Homol. A-5036  
 Make \_\_\_\_\_ Model \_\_\_\_\_

d) Matériau du capot AV Front bonnet material	Mild steel sheet pressing
e) Matériau du capot/hayon AR Rear bonnet / tailgate material	Mild steel sheet pressing
f) Matériau de la carrosserie Bodywork material	Mild steel sheet pressing
g) Matériau du pare-brise Windscreen material	Laminated glass only for competition use
h) Matériau de la lunette AR Rear window material	Safety glass
i) Matériau des glaces de custode Rear quarter lights material	Safety glass
k) Matériau des vitres latérales Side window material	AV / Front Safety glass AR / Rear Safety glass
l) Matériau du pare-choc avant Material of the front bumper	Mild steel/plastic
m) Matériau du pare-choc arrière Material of the rear bumper	Mild steel

**INFORMATIONS COMPLEMENTAIRES**

**COMPLEMENTARY INFORMATION**

Alternative final drives 4,11 = 9 : 37  
 (Art. 605) 4,63 = 8 : 37

Photo : Alternative manual gear box

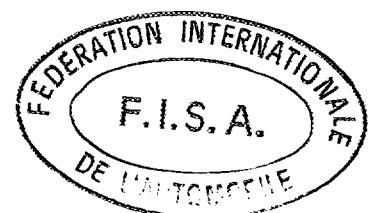
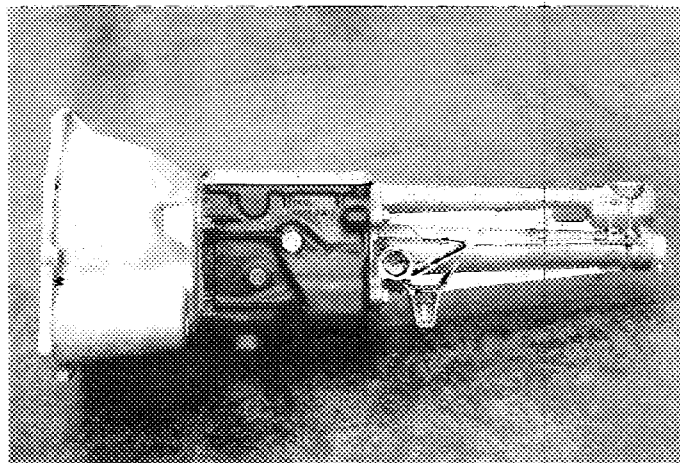

Marque  
Make

FORD

Modèle  
Model

RS2000

N° Homol.

A-5036

**PHOTOS / PHOTOS**

**Moteur / Engine**

C) Profil droit du moteur déposé  
Right hand view of dismantled engine

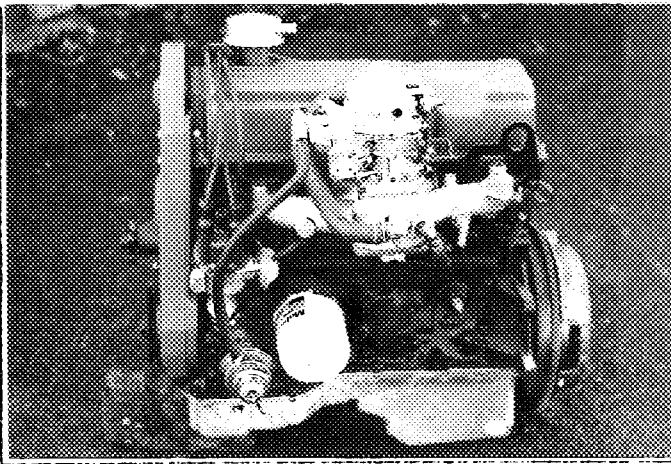

D) Profil gauche du moteur déposé  
Left hand view of dismantled engine

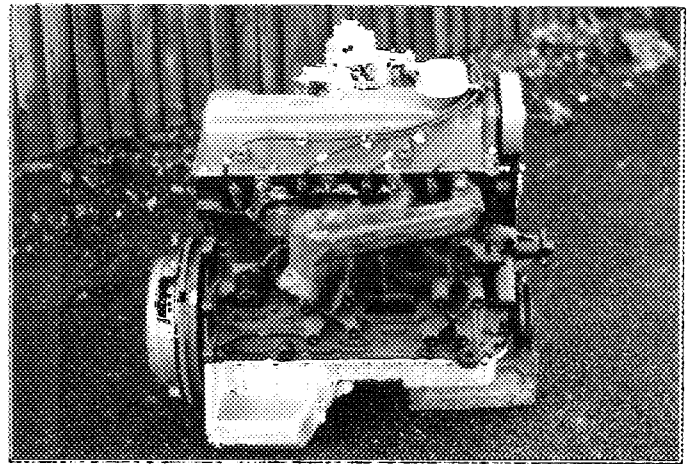

E) Moteur dans son compartiment  
Engine in its compartment

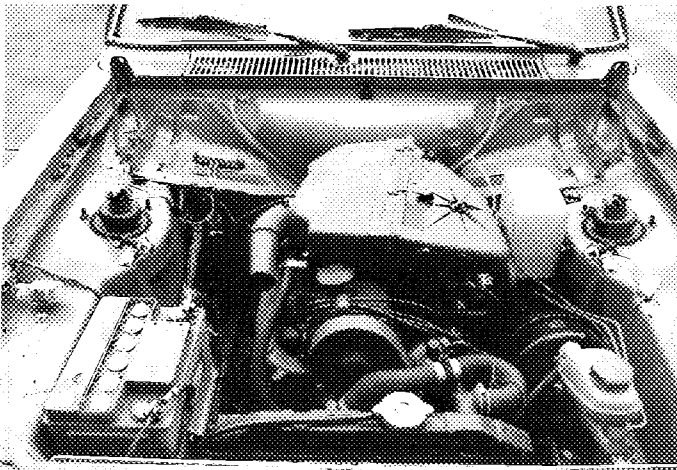

F) Culasse nue  
Bare cylinderhead

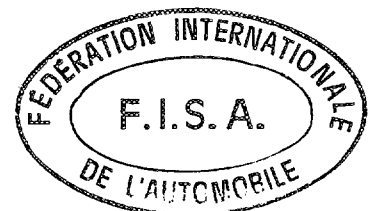
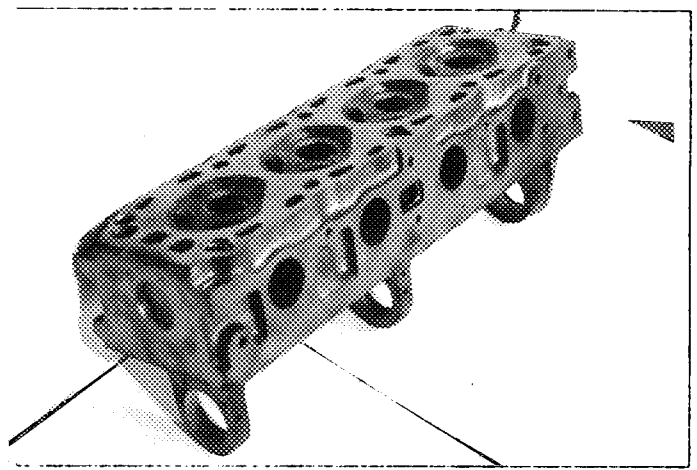

Marque  
Make

FORD

Modèle  
Model

RS2000

N° Homol.

A-5036

G) Chambre de combustion  
Combustion chamber

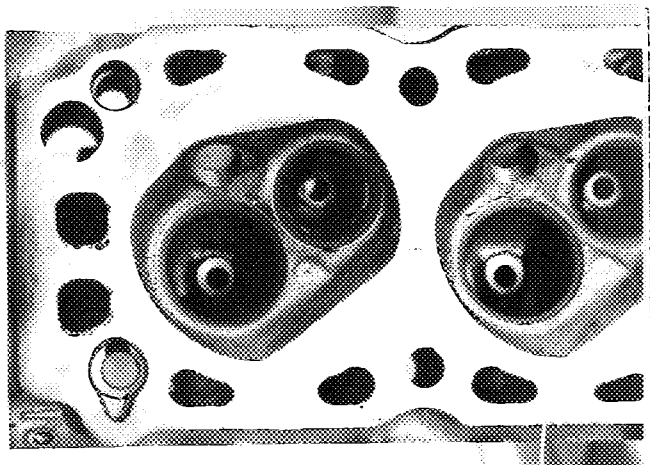

H) Carburateur(s) ou système d'injection  
Carburetor(s) or injection system

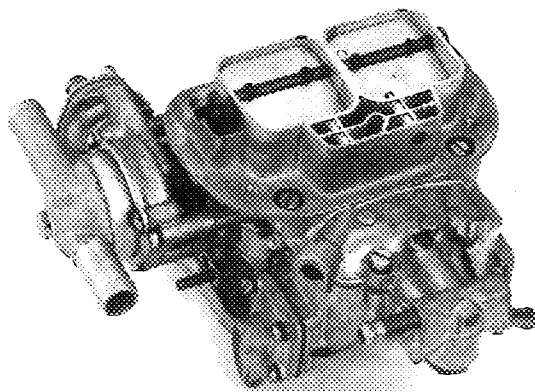

I) Collecteur d'admission  
Inlet manifold

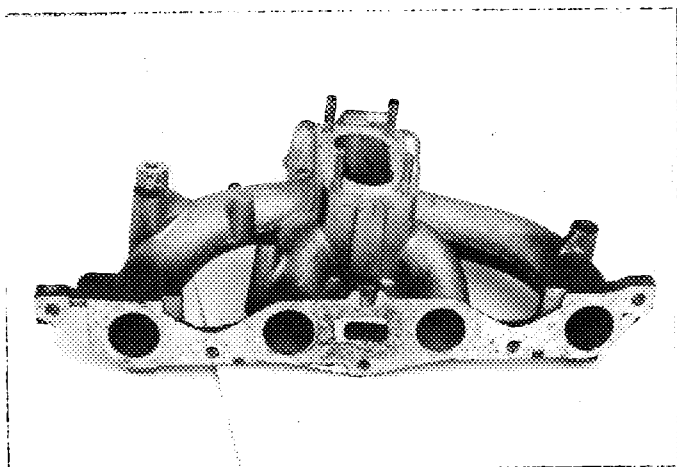

J) Collecteur d'échappement  
Exhaust manifold

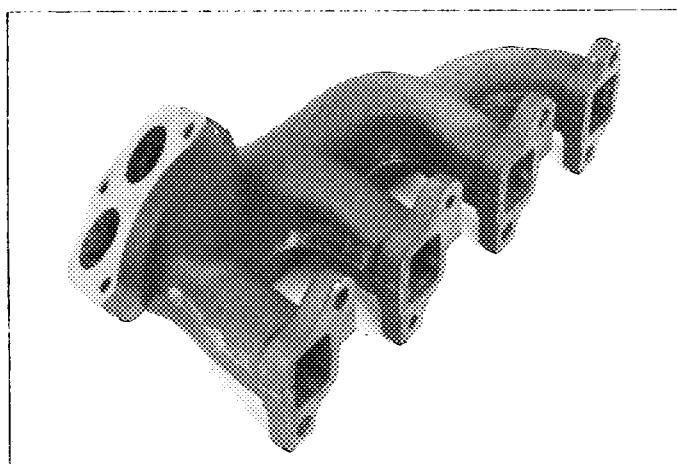

### Transmission / Transmission

S) Carter de boîte de vitesse et cloche d'embrayage  
Gearbox casing and clutch bellhousing

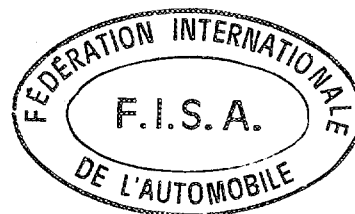
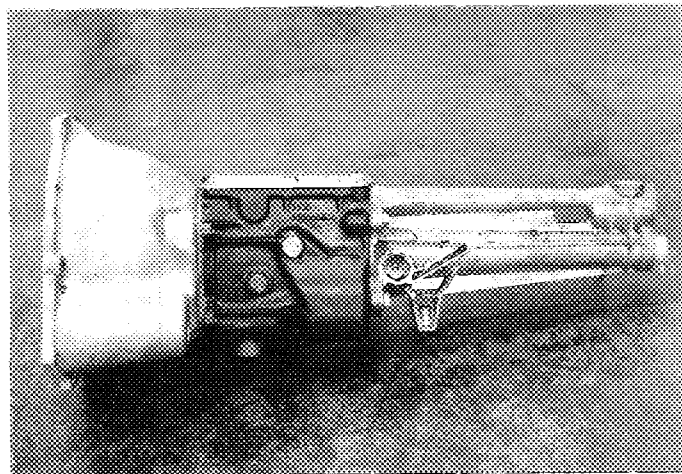

Marque  
Make

FORD

Modèle  
Model

RS 2000

N° Homol. A-5036

**Suspension / Suspension**

T) Train avant complet déposé  
Complete dismantled front running gear

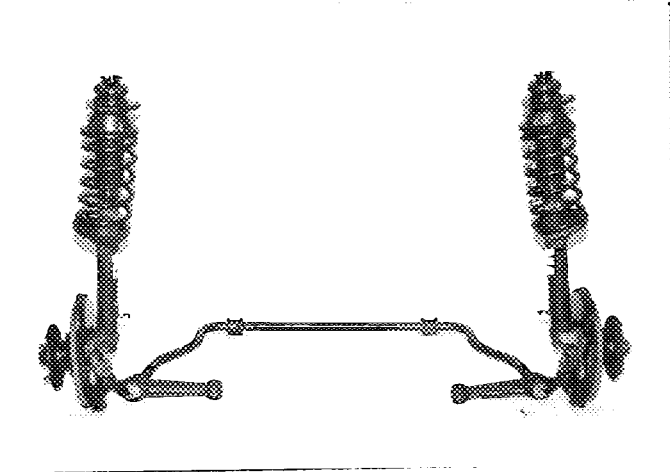

U) Train arrière complet déposé  
Complete dismantled rear running gear

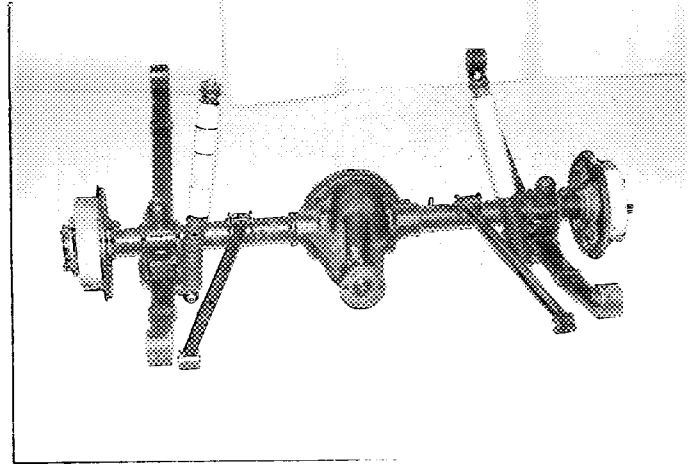

**Train roulant / Running gear**

V) Freins avant  
Front brakes

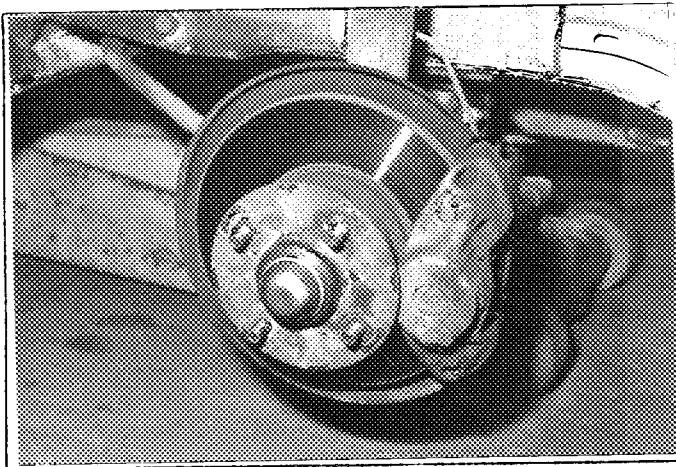

W) Freins arrière  
Rear brakes

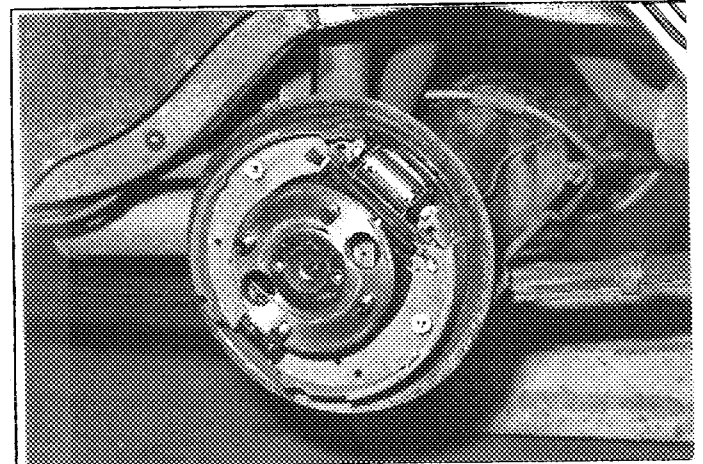

**Crosserie / Bodywork**

X) Tableau de bord  
Dashboard

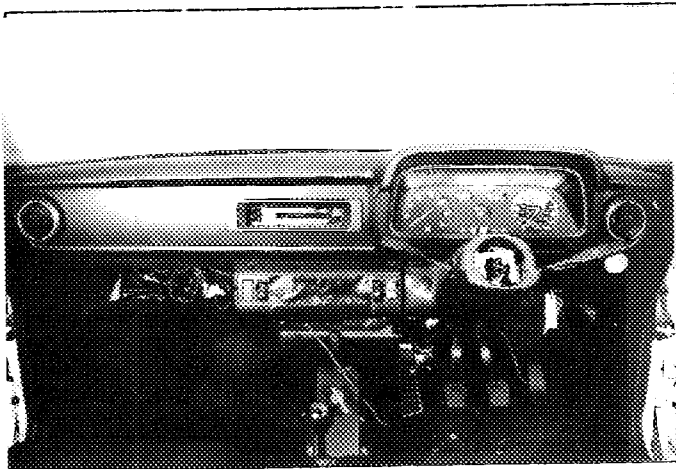

Y) Toit ouvrant  
Sunroof

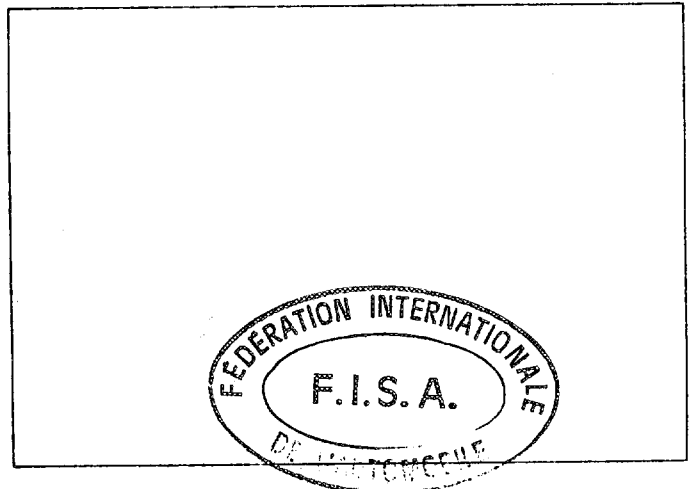

DESSINS / DRAWINGS

Moteur / Engine

I Orifices d'admission de la culasse, face collecteur (tolérances sur dimensions: -2%, +4%)  
 Cylinderhead inlet ports, manifold side (tolerances on dimensions: -2%, +4%)

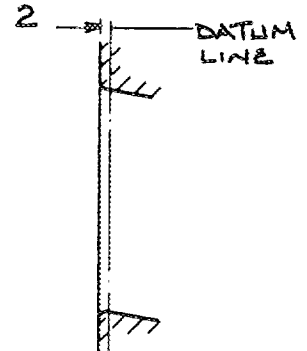
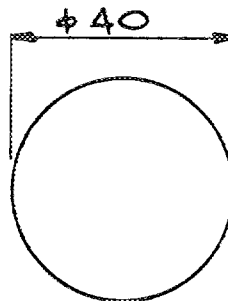

II Orifices du collecteur d'admission, côté culasse (tolérances sur dimensions: -2%, +4%)  
 Inlet manifold ports, cylinderhead side (tolerances on dimensions: -2%, +4%)

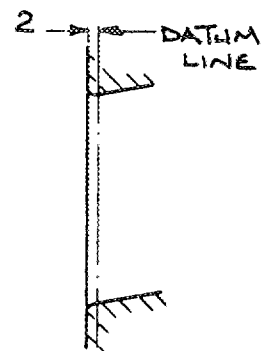
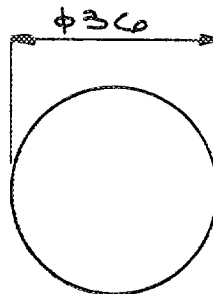

III Orifices d'échappement de la culasse, face collecteur (tolérances sur dimensions: -2%, +4%)  
 Cylinderhead exhaust ports, manifold side (tolerances on dimensions: -2%, +4%)

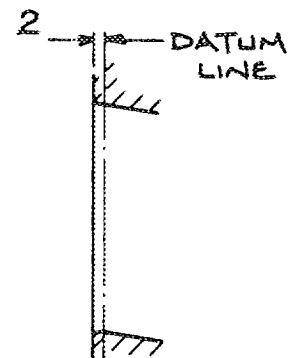
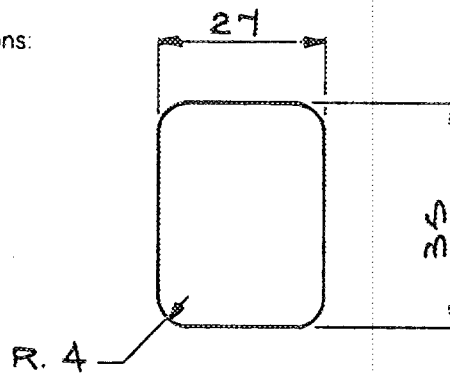

IV Orifices du collecteur d'échappement, côté culasse (tolérances sur dimensions: -2%, +4%)  
 Exhaust manifold ports, cylinderhead side (tolerances on dimensions: -2%, +4%)

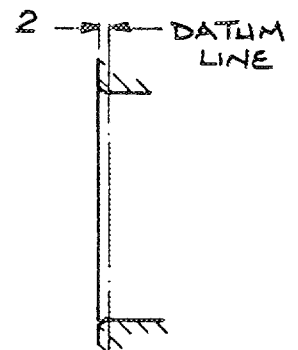
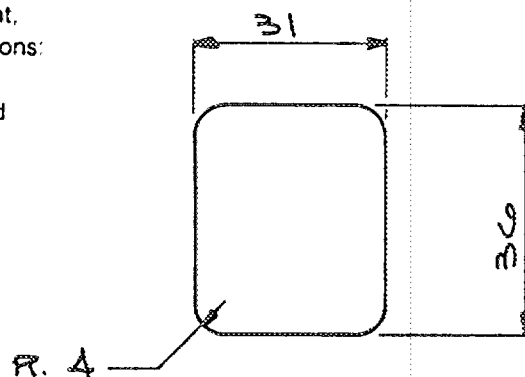

Marque  
Make

FORD

Modèle  
Model

RS2000

N° Homol

A-5036

**Suspension / Suspension**

- XV Système de suspension, selon l'article 705 ou en remplacement des photos O et P.  
Suspension system according to article 705 or replacing photos O and P.

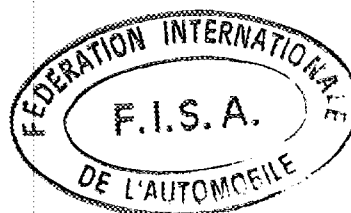



# FEDERATION INTERNATIONALE DU SPORT AUTOMOBILE

Homologation N°

A-5036

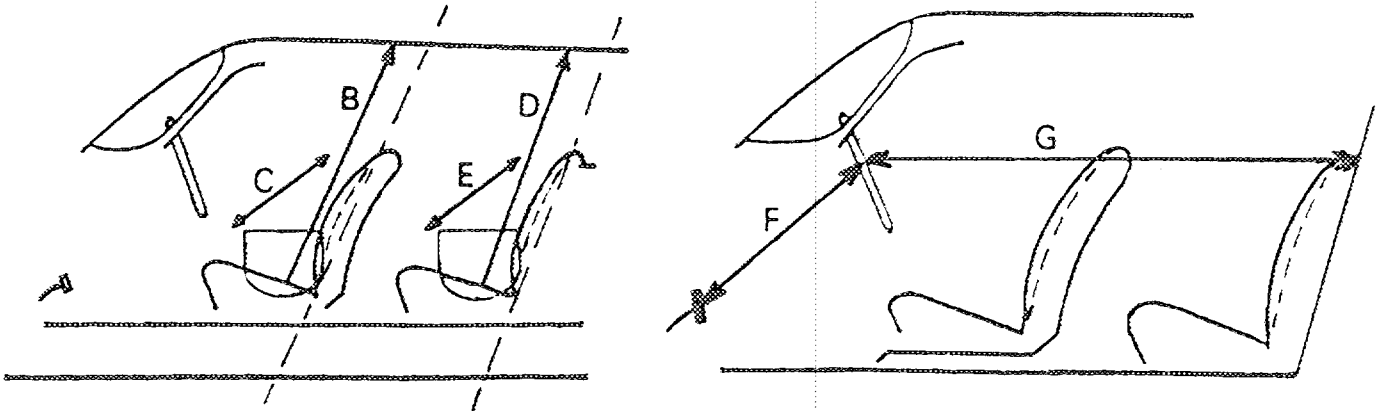
Groupe **A/B**  
GroupMarque FORD Modèle RS2000  
Make \_\_\_\_\_ Model \_\_\_\_\_Dimensions intérieures comme définies par le Règlement d'Homologation  
Interior dimensions as defined by the Homologation Regulations.

B (Hauteur sur sièges avant) (Height above front seats)	1000	mm
C (Largeur aux sièges avant) (Width at front seats)	1270	mm
D (Hauteur sur sièges arrière) (Height above rear seats)	920	mm
E (Largeur aux sièges arrière) (Width at rear seats)	1275	mm
F (Volant — Pédale de frein) (Steering wheel — brake pedal)	620	mm
G (Volant — paroi de séparation arrière) (Steering wheel — rear bulkhead)	1490	mm
H = F+G =	2110	mm

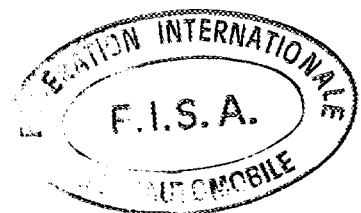





# FEDERATION INTERNATIONALE DU SPORT AUTOMOBILE

Homologation N°

A-5036

Extension N°

01/01VF

## FICHE D'EXTENSION A L'HOMOLOGATION OFFICIELLE FISA FORM OF EXTENSION TO THE OFFICIAL FISA HOMOLOGATION

ET Evolution normale du type: dès le numéro de châssis  
Normal evolution of the type: as from chassis number

VF Variante de fourniture / Supply variant

VO Variante option / Option variant

ER Errata / Erratum

Homologation valable dès le \_\_\_\_\_ -1. JUIN 1982  
Homologation valid as from \_\_\_\_\_

en groupe \_\_\_\_\_  
in group \_\_\_\_\_

Constructeur \_\_\_\_\_ FORD  
Manufacturer \_\_\_\_\_

Modèle et type \_\_\_\_\_ Escort 2 litre  
Model and type \_\_\_\_\_

Page ou ext Page or ext.	Art. Art.	Description Description
	313	Dry, cast iron liners are a factory reclaim procedure - the customer having no option.
	327e & 328f	Valve stem oversize at 8,2 and 8,4 mm are factory reclaim - the customer having no option.

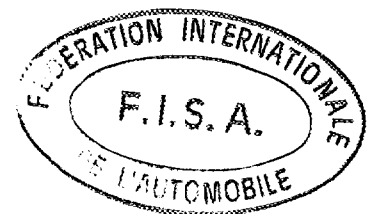



# FEDERATION INTERNATIONALE DU SPORT AUTOMOBILE

Homologation N°

A - 5036

Extension N°

02 / 01 V0

FICHE D EXTENSION A L'HOMOLOGATION OFFICIELLE FISA  
FORM OF EXTENSION TO THE OFFICIAL FISA HOMOLOGATION

**ET** Evolution normale du type: dès le numéro de châssis  
Normal evolution of the type: as from chassis number

**VF** Variante de fourniture / Supply variant

**VO** Variante option / Option variant

**ER** Errata / Erratum

Homologation valable dès le \_\_\_\_\_ en groupe  
Homologation valid as from 02/01/1982 in group \_\_\_\_\_

Constructeur FORD Modèle et type Escort 2 litre  
Manufacturer \_\_\_\_\_ Model and type \_\_\_\_\_

Page ou ext Page or ext	Art. Art.	Description Description
7	701	Combined radius rods and anti roll bar - see photo 81-3
	707	Heavy duty hub - alum alloy complete with increased capacity bearings - see photo 81-4
8	707	Reinforced suspension element incorporating increase damper capacity - body O.D. = 51 mm See photo 81-5
7	701	Reinforced front suspension mount (4 bolt clamp) See photo 81-6
7	701	Reinforced front suspension incorporating redesigned tie bars and anti roll bars. Kinematics unaltered. See photo 81-7

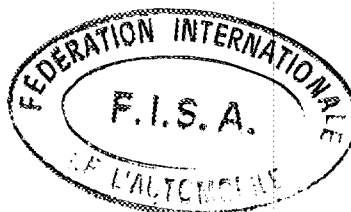

Marque  
Make

FORD

Modèle  
Model

Escort 2 litre

N° Homol.

A-5036

VO

N° Ext.

02 / 0100

Page ou ext. Page or ext.	Art. Art	Description Description
7	606	One piece engine to axle drive shaft using needle rollers and sliding spline See photo 81-8
7	606b	Two piece half shaft plus increased bearing capacity See photo 81-9
8	803	Disc brake rear axle conversion incorporating heavy duty bearing, carrier and hub assembly See photo 81-10
8	803bl	Dual circuit brake box. Cylinder sizes may be 15,87; 17,78; 19,05; 20,6 mm dia. Brake fluid reservoir is not inside habitacle. See photo 81-11
8	803c	Brake boost - fitted in line, is optional
8	803cl	Vacuum assist
9	804	Quick ratio steering Ratio = 14:1
Alternative brakes:		
<u>Front</u>		
8	803e	4
8	803g1	2
9	803g3	Aluminium alloy Shown on photo 81-12
9	803g4	20,7 mm
9	803g6	262 mm
9	803g10	672,3 cm <sup>2</sup> Shown on photo 81-12
8	803e1	38,1
8	803g2	1
9	803g8	112 mm
9	803g5	264 mm
9	803g7	160 mm
9	803g9	Ventilated
<u>Rear</u>		
8	803e	2
8	803g1	2
9	803g3	Cast iron For use with vented and non vented disc See photo 81-13
8	803e1	38mm
8	803g2	1
9	803g8	62 mm
8	803e	2
8	803g1	2
9	803g3	Aluminium alloy For use with vented and non vented disc See photo 81-14
8	803e1	51 mm
8	803g2	1
9	803g8	75 mm

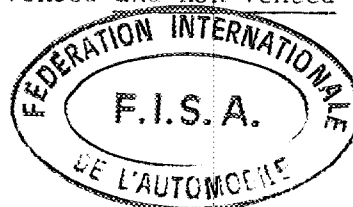

Marque Make FORD Modéle Model Escort 2 litre N° Homol. \_\_\_\_\_

VO

N° Ext. 02 / 01V0

Page ou ext. Page or ext.	Art. Art.	Description Description
9	803g4 803g6 803g10	13 mm 263 mm 704,2 cm <sup>2</sup> See photo 81-15
9	803g4 803g6 803g10	20,7 mm 262 mm 676,1 cm <sup>2</sup> See photo 81-16
		<u>Alternative brakes</u>
		<u>Front</u>
	803e 803g1 803g3	2 2 Cast iron
	803g4 803g6 803g10	20mm 243 mm 637,0 cm <sup>2</sup> See photo 81-21
		803e1 54 mm 803g2 1 803g8 77 mm
		803g5 244 mm 803g7 136 mm 803g9 Ventilated
8	803g2	For improved handbrake the following kit is available: Master cylinder 17,8 or 19,1 mm bore This increases number of calipers/wheel for rear axle to 2. See photo's 81-17 & 18
8	803e	2
8	803g1	2
9	803g3	Aluminium alloy
		803e1 57 mm 803g2 1 803g8 75 mm
		Alternative main rear axle caliper when using hydraulic handbrake kit - see photo 81-19

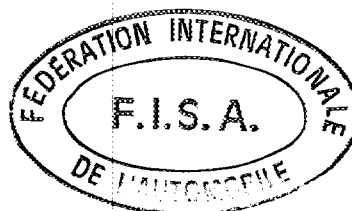

PHOTOS / PHOTOS

N° Ext. 02701V0

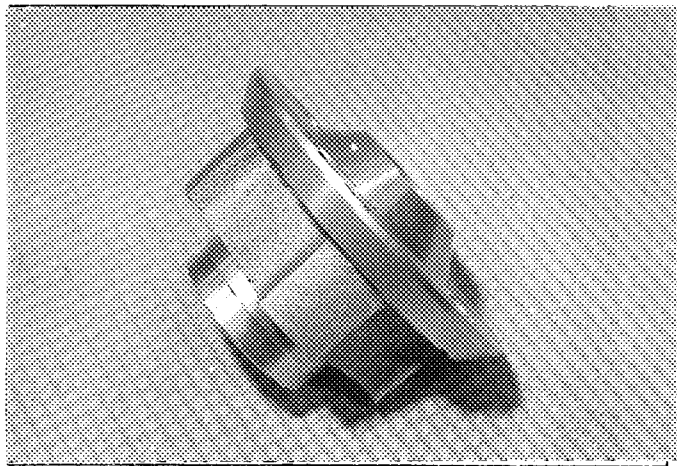

81-4

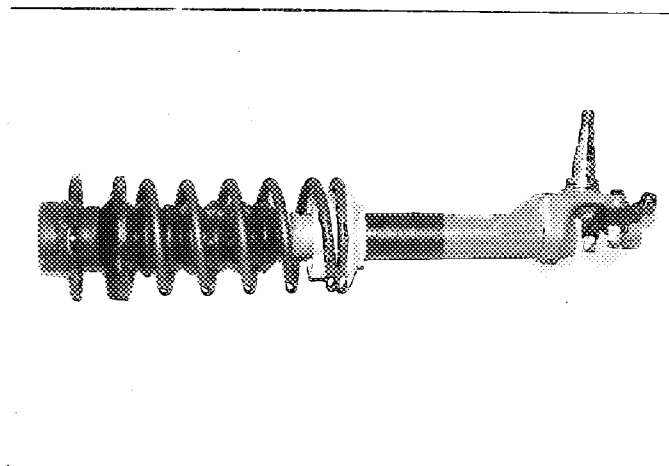

81-5

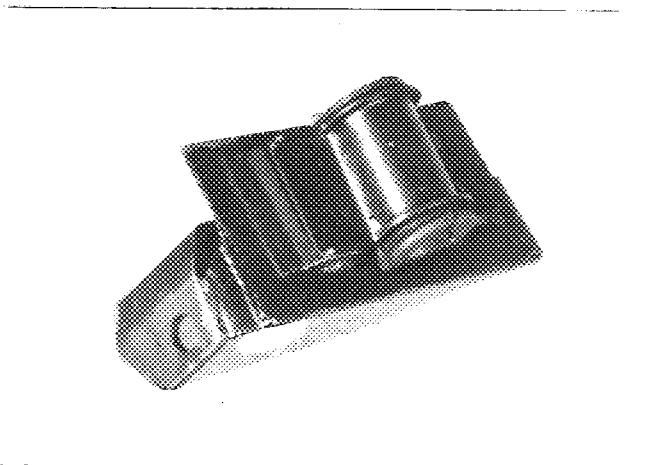

81-6

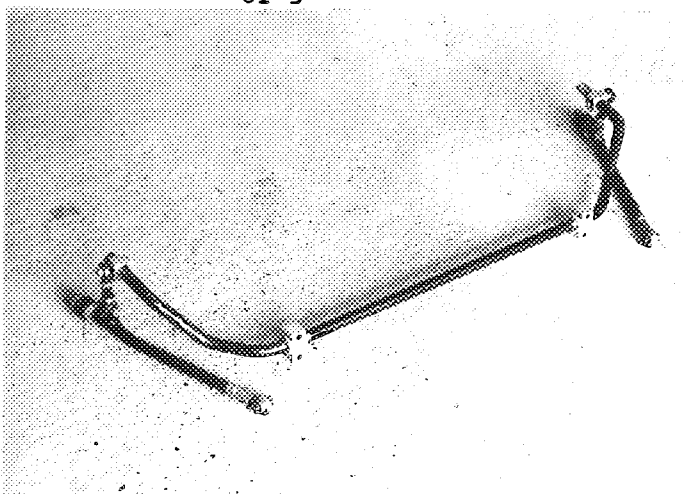

81-7

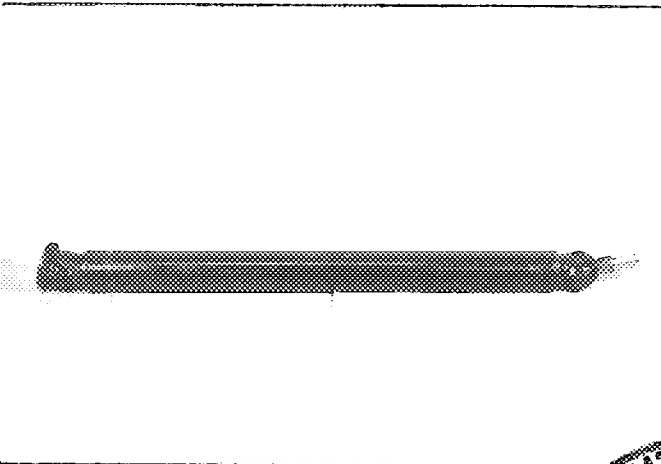

81-8

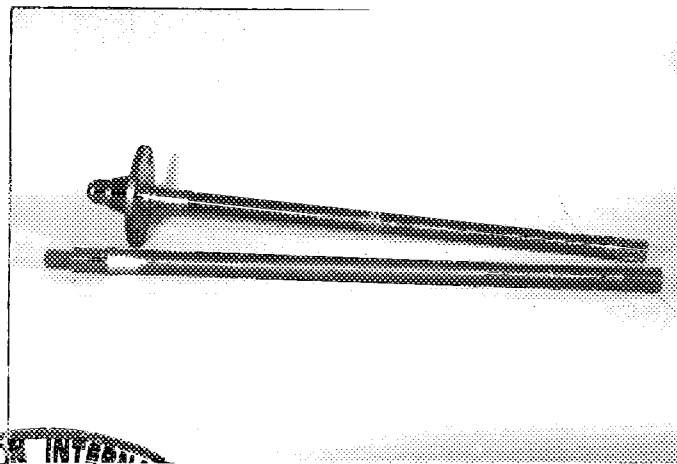

81-9



Marque  
Make

FORD

Modèle  
Model

RS 2000

N° Homol. A-5036

PHOTOS / PHOTOS

N° Ext. 02/01V0

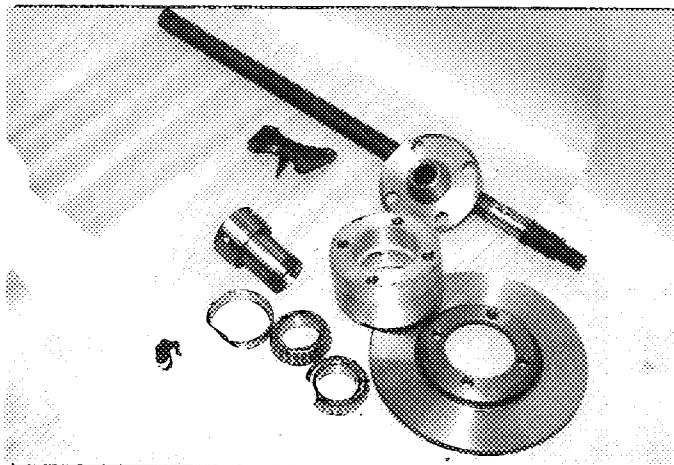

81-10

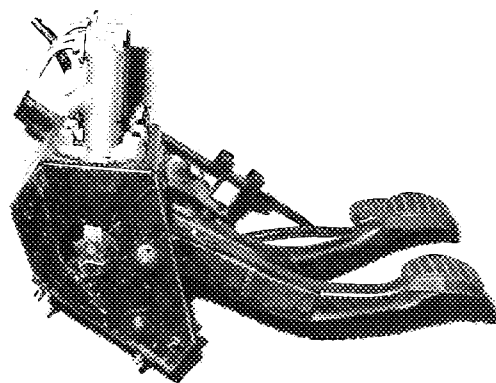

81-11

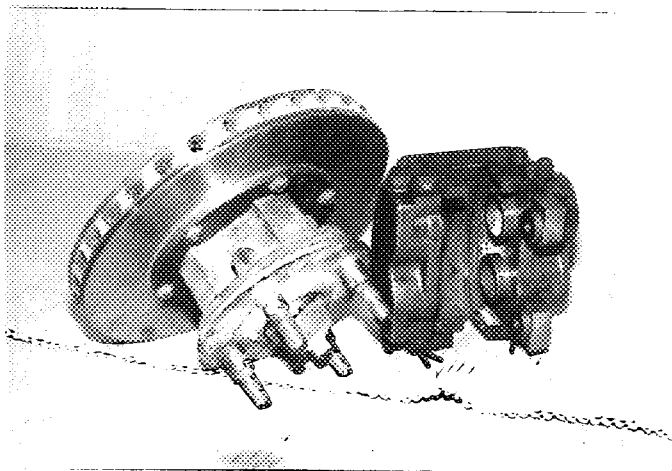

81-12

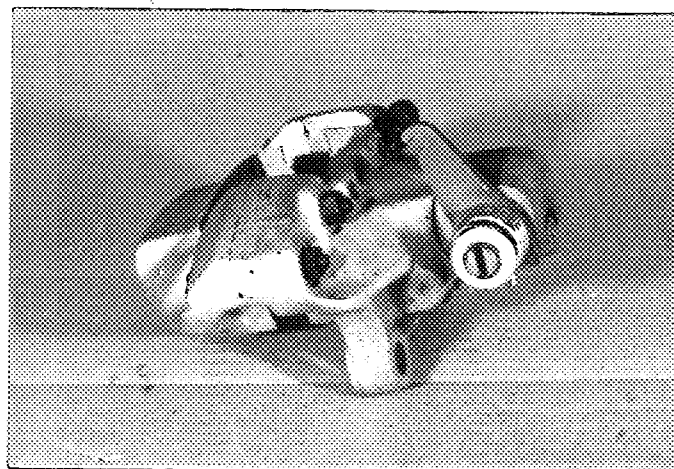

81-13

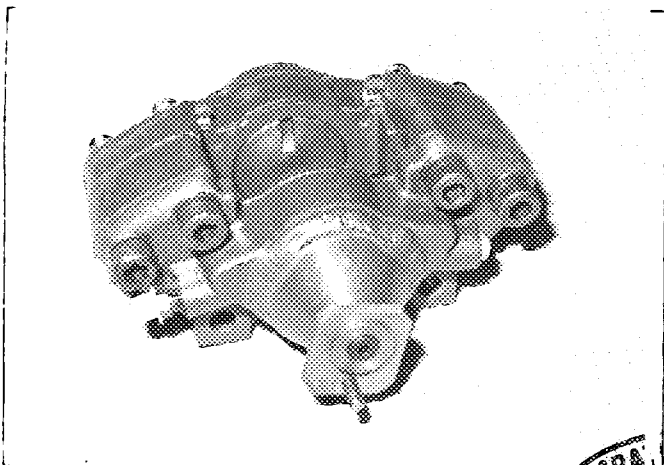

81-14

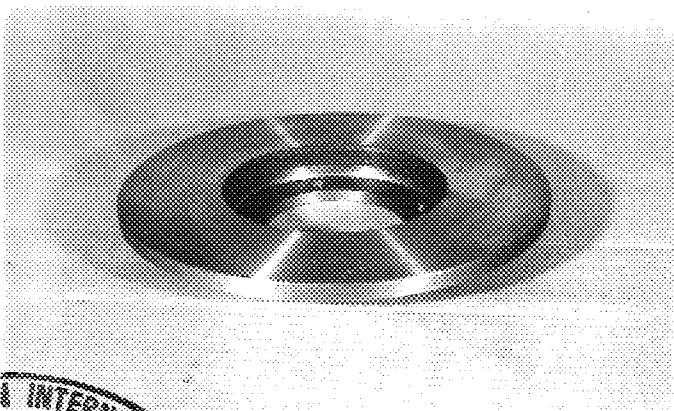

81-15

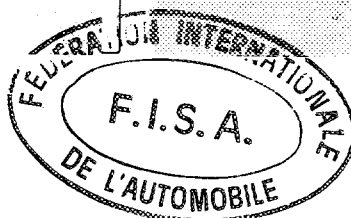

PHOTOS / PHOTOS

N° Ext. 02 / 01V0

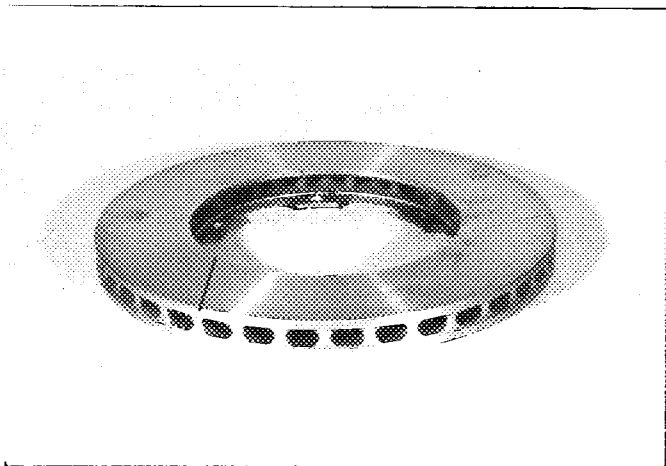

81-16

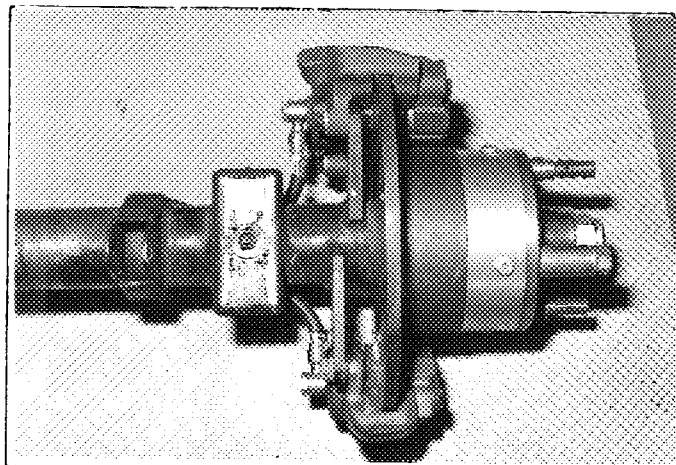

81-17

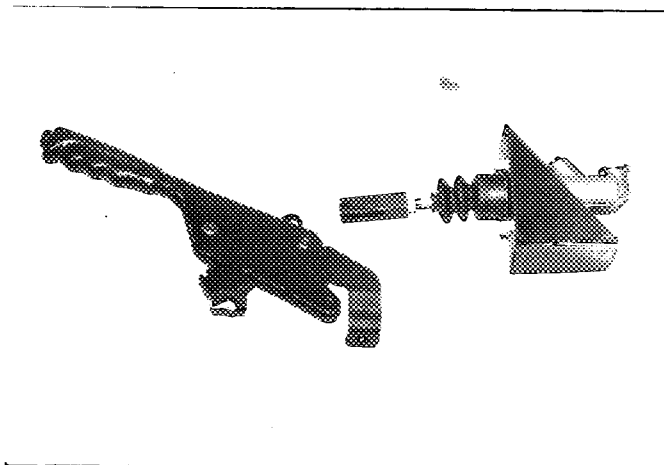

81-18

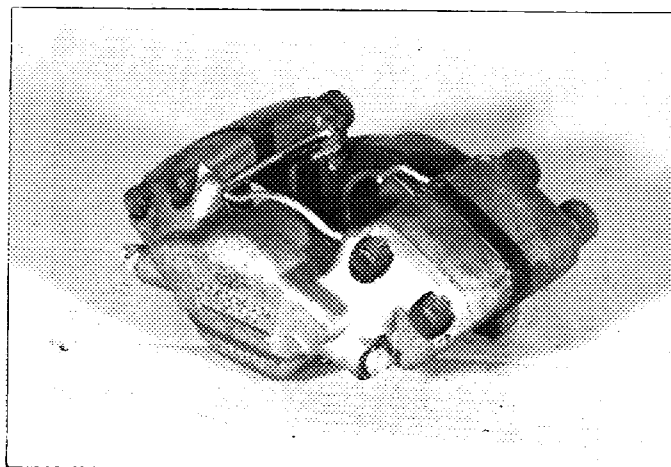

81-19

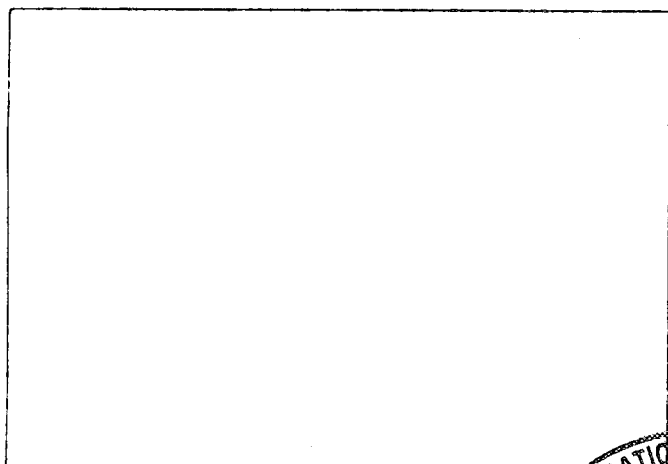

81-20

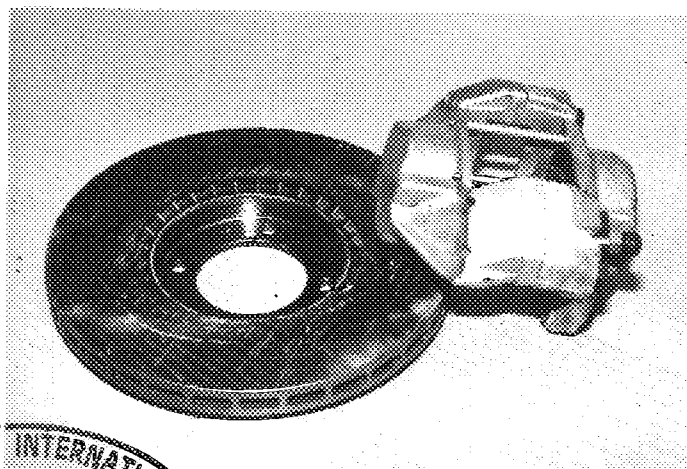

81-21

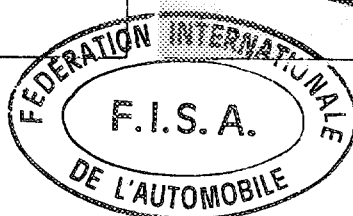



# FEDERATION INTERNATIONALE DU SPORT AUTOMOBILE

Homologation N°

**A - 5036**

Extension N°

**03 / 01 ER**

FICHE D'EXTENSION A L'HOMOLOGATION OFFICIELLE FISA  
FORM OF EXTENSION TO THE OFFICIAL FISA HOMOLOGATION

**ET** Evolution normale du type: dès le numéro de châssis  
Normal evolution of the type: as from chassis number \_\_\_\_\_

**VF** Variante de fourniture / Supply variant

**VO** Variante option / Option variant

**ER** Errata / Erratum

Homologation valable dès le  
Homologation valid as from

**- 1 OCT. 1983**

en groupe **A**  
in group

Constructeur  
Manufacturer **FORD**

Modèle et type  
Model and type **escort 2000 RS**

Page ou ext.  
Page or ext.

Art.  
Art.

Description  
Description

Page 6

603e

	B.V. suppl. / Additional G.B.		
	rappports ratio	nombre de dents/ number of teeth	synchro.
1			
2			
3	1,25	$\frac{22}{28}$	
4			
5			
AR/R Const- tante Const- tant.			

au lieu de :  
instead of :

	B.V. suppl. / Additional G.B.		
	rappports ratio	nombre de dents/ number of teeth	synchro.
1			
2			
3	1,25	$\frac{25}{24}$	
4			
5			
AR/R Const- tante Const- tant.			

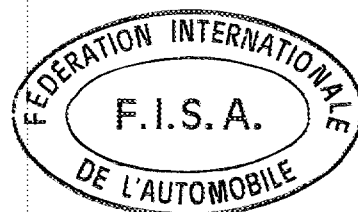





FORD - ESCORT RS 2000 AUS.

MARQUE ET MODELE

6/82 -

VALIDITE HOMOLOGATION

A 5036

FICHE NR.

A / 2000

GROUPE / CLASSE

EXTENSIONS	DEBUT VALIDITE	DESCRIPTION	NOTES
01/01VF	6/82	CAMEUSE - SOUPAPE	
02/01V0	6/82	SUSPENSION - TRANSMISSION -	
		FREIN	
03/01ER	10/83	RAPPORT	

Autres homologations du modèle B 215

Vérifiée le 24/12/85 par [Signature] visée ce jour le \_\_\_\_\_ par \_\_\_\_\_